

25,285 SF

Industrial Space For Lease



Prologis Centerport 200



700 NW 33rd Street
Pompano Beach, FL 33064 USA



LOCATION

- Conveniently located with excellent access to Interstate 95, the Florida Turnpike, and the Sawgrass Expressway
- Easy access to Sample Road, Copans Road, and Powerline Road

FACILITY

- Suite 280
- 94,820 SF – total building
- 25,285 SF available with 2,218 SF of spec office
- 24' ceiling height
- 9 dock high doors, 7 with pit levelers
- 1 oversized drive-in ramp
- Available Immediately

ADVANTAGES AND AMENITIES

- Geographically central to service the Tri-County area of Broward, Palm Beach, and Miami-Dade Counties.
- Immediate access to I-95 with Florida's Turnpike and the Sawgrass Expressway just minutes away.
- Prologis Clear Lease[®] - Know your lease expenses and capital cost with greater certainty

Your single-source service for efficient move-in and operations: [prologisessentials.com](https://www.prologisessentials.com)



Scan the QR code for more info!

25,285 SF

Industrial Space For Lease



Prologis Centerport 200

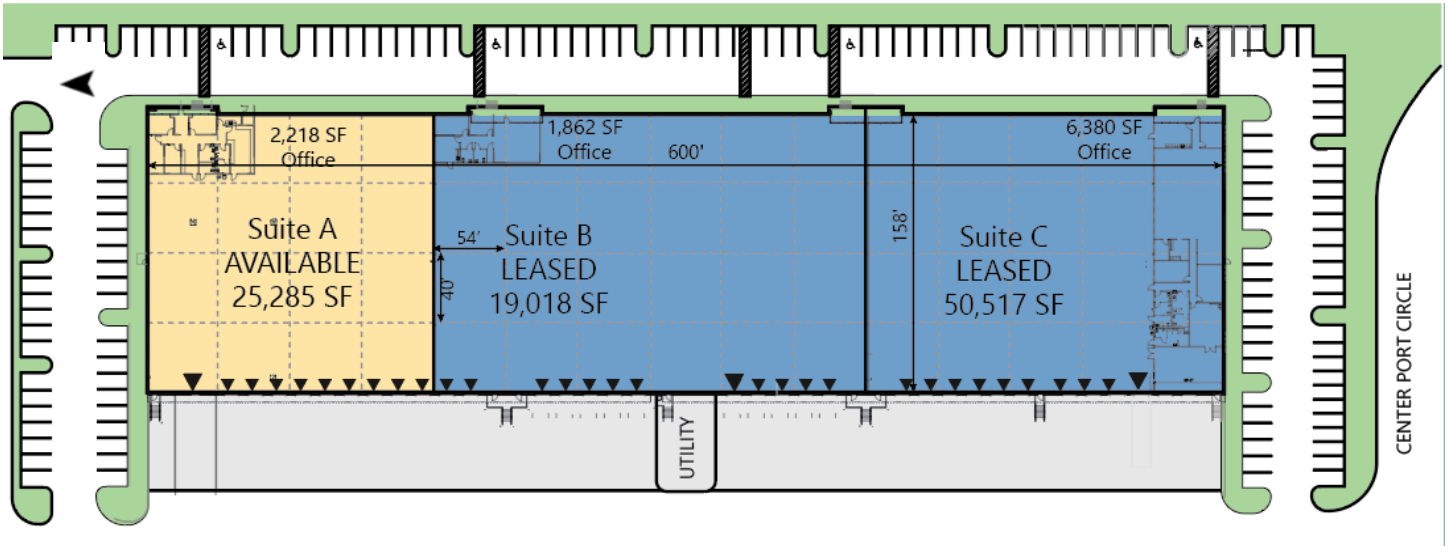

2,218 SF Office

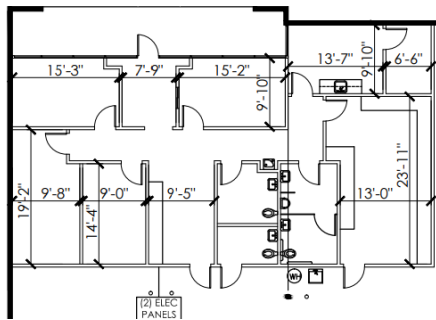

Legend:

- ▲ DOCK DOOR
- ▲ DRIVE-IN DOOR
- AVAILABLE
- LEASED
- LAND



Cushman & Wakefield
Chris J. Metzger, SIOR
chris.metzger@cushwake.com
ph +1 954 771 0800
cell +1 954 415 9155
225 NE Mizner Boulevard
Suite 300
Boca Raton, FL 33432 USA

Prologis
Ashley McMullen
amcmullen@prologis.com
ph +1 954 316 1778
cell +1 954 909 3022
201 East Las Olas Boulevard
Suite 1550
Fort Lauderdale, FL 33301 USA