

9,600 SF

Industrial Space For Lease



Prologis NW Corporate Park



3549 NW Yeon Avenue - Bldg 5
Portland, OR 97210 USA

LOCATION

- Guilds Lake / NW Industrial Area
- Ten (10) Buildings; 678,026 SF Park

FACILITY

- Approximately 9,600 SF with 1,894 SF Office
- One (1) Dock-High Door and One (1) Grade Door
- Fully Sprinklered
- 24' Clear Height
- Racking in-place. Available for sale.

ADVANTAGES AND AMENITIES

- Close-In NW Location
- Minutes to Downtown Portland
- Immediate Access to I-405 and I-5
- Park Amenities Include Food and Convenience Services
- Please Call Brokers for Current Rates

Your single-source service for efficient move-in and operations: [prologisessentials.com](https://www.prologisessentials.com)



9,600 SF

Industrial Space For Lease



Prologis NW Corporate Park

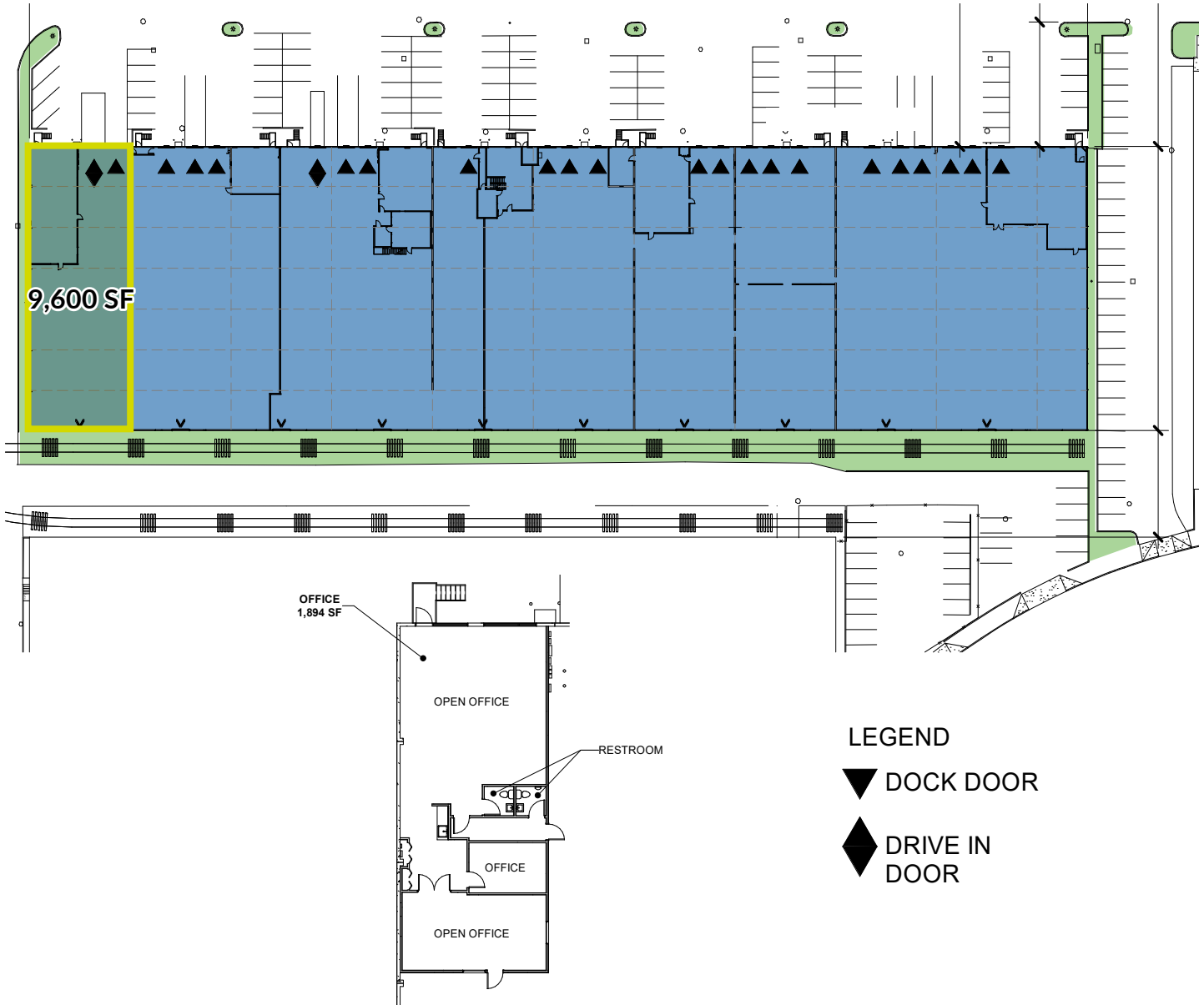

Capacity Commercial Group
Scott Kappes, SIOR
scottk@capacitycommercial.com
ph +1 503 517 9877
cell +1 503 816 4201
805 SW Broadway Street,
Suite 600,
Portland, OR 97205 USA

Capacity Commercial Group
Kenny Houser, SIOR
kenny@capacitycommercial.com
ph +1 503 517 9875
cell +1 503 385 6080
805 SW Broadway Street,
Suite 600,
Portland, OR 97205 USA

Prologis
Kurt Nelson
knelson@prologis.com
ph +1 503.276.7361
4380 SW Macadam Avenue
Suite 440
Portland, OR 97239

No warranty or representation, expressed or implied, is made as to the accuracy of the information contained herein, and same is submitted subject to error and omissions.

9,600 SF

Industrial Space For Lease



Prologis NW Corporate Park

Racking Solutions

We can provide a custom design that's right for your operation!

RACK LAYOUT

- 252 Total Pallet Positions
- 12'-0" Aisle (Typical)
- New and Used Racking Available

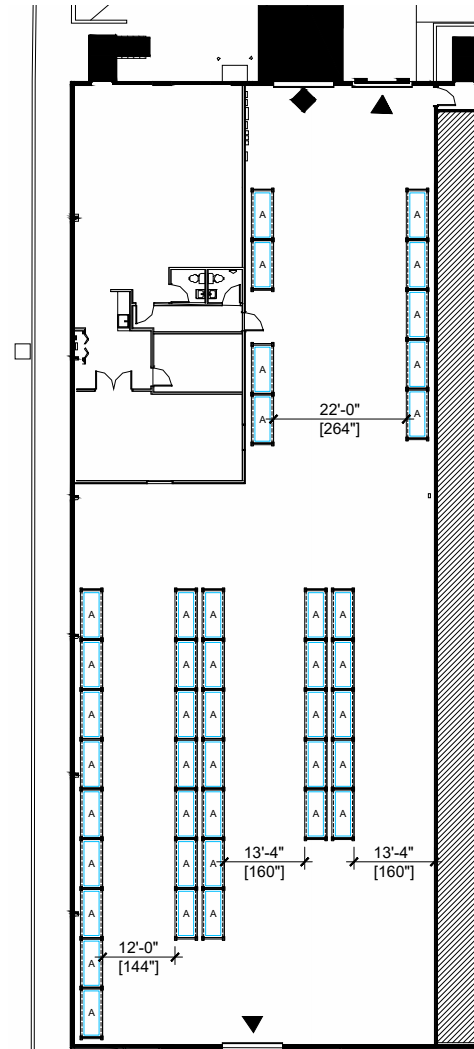
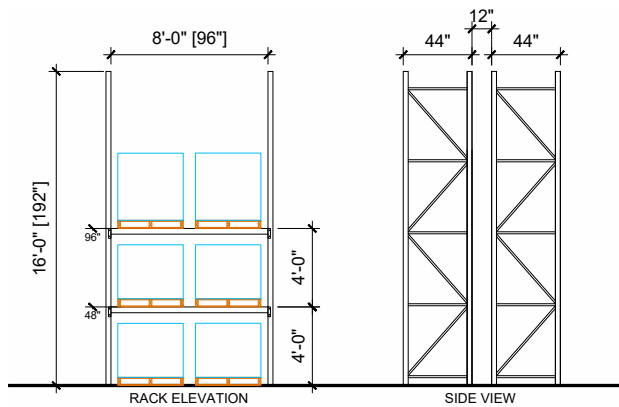

For Racking Designs, Inquiries, and Pricing, Please Contact:

Brannan Morris | Essentials Solutions Manager

bmorris@prologis.com

Direct +1 (206) 414-7624 | Mobile +1 (847) 204-3612



Capacity Commercial Group

Scott Kappes, SIOR
scottk@capacitycommercial.com
ph +1 503 517 9877
cell +1 503 816 4201
805 SW Broadway Street,
Suite 600,
Portland, OR 97205 USA

Capacity Commercial Group

Kenny Houser, SIOR
kenny@capacitycommercial.com
ph +1 503 517 9875
cell +1 503 385 6080
805 SW Broadway Street,
Suite 600,
Portland, OR 97205 USA

Prologis

Kurt Nelson
knelson@prologis.com
ph +1 503.276.7361
4380 SW Macadam Avenue
Suite 440
Portland, OR 97239